

HITACHI

DASH 3



ZAXIS 350LC-3

- Engine Rated Power: 271 SAE net hp (202 kW) @ 1,900 rpm
- Operating Weight: 77,269 lb. (35 049 kg)
- Backhoe Bucket: 2.3 cu. yd. (1.76 m³), 54 in. (1370 mm)

ZAXIS 350LC-3 SPECIFICATIONS

Engine

Model	Isuzu AH-6HK1XYSA-01
	meets EPA and CARB emissions non-road regulations
Type	4-cycle water-cooled, direct injection
Aspiration	turbocharged, intercooled
No. of Cylinders	6
Rated Power	
SAE J1349, net	H/P mode: 271 hp (202 kW) at 1,900 rpm (min ⁻¹)
Piston Displacement	475 cu. in. (7.790 L)
Bore and Stroke	4.5 in. x 4.9 in. (115 mm x 125 mm)
Electrical System	24 volt with 50-amp alternator

Hydraulic System

Main Pumps	two variable-displacement axial-piston
Maximum Flow	2 x 76.1 gpm (2 x 288 L/min.)
Pilot Pump	one gear
Maximum Flow	8.9 gpm (34 L/min.)
Pressure Setting	580 psi (4000 kPa)

System Operating Pressure

Implement Circuits	4,980 psi (34 300 kPa)
Travel Circuits	4,980 psi (34 300 kPa)
Swing Circuits	4,700 psi (32 400 kPa)
Power Boost	5,260 psi (36 300 kPa)
Oil Filtration	one 10-micron full-flow return filter with by-pass / one pilot oil filter

Cylinders

	Bore	Rod Diameter	Stroke
Boom (2)	5.7 in. (145 mm)	3.9 in. (100 mm)	59.8 in. (1520 mm)
Arm (1)	6.7 in. (170 mm)	4.5 in. (115 mm)	68.5 in. (1740 mm)
Bucket (1)	5.5 in. (140 mm)	3.7 in. (95 mm)	49.2 in. (1250 mm)

Swing Mechanism

Swing Speed	0–10.7 rpm
Swing Torque	81,950 lb.-ft. (111 194 Nm)

Undercarriage

Carrier Rollers (per side)	2
Track Rollers (per side)	8
Shoes, Triple Semi-Grouser (per side)	48
Track Guides	front, center, and rear
Track Adjustment	hydraulic
Travel Speed	
Low	0–2.0 mph (0–3.2 km/h)
High	0–3.4 mph (0–5.5 km/h)
Drawbar Pull	67,928 lb. (30 812 kg)

Ground Pressure Data

Average Ground Pressure

32-in. (800 mm) Triple Semi-Grouser Shoes (recommended for general/soft terrain)	7.16 psi (49.4 kPa)
--	---------------------

SAE Operating Weights

With Full Fuel Tank; 175-lb. (79 kg) Operator; 2.3-cu.-yd. (1.76 m³), 54-in. (1370 mm), 2,557-lb. (1160 kg) Bucket; 13-ft. 1-in. (4.0 m) Arm; 16,314-lb. (7400 kg) Counterweight; and 32-in. (800 mm) Triple Semi-Grouser Shoes77,269 lb. (35 049 kg)

Capacities (U.S.)

Fuel Tank	166 gal. (630 L)
Cooling System	33.8 qt. (32 L)
Engine Lubrication, Including Filter	43.3 qt. (41 L)
Hydraulic Tank	51.5 gal. (195 L)
Hydraulic System	89.8 gal. (340 L)
Propel Gearbox (each)	9 qt. (8.5 L)
Swing Drive	12.5 qt. (11.8 L)

Component Weights

Undercarriage

with 32-in. (800 mm) Triple Semi-Grouser Shoes	28,020 lb. (12 710 kg)
One-Piece Boom (with arm cylinder)	6,682 lb. (3031 kg)

Arm with Bucket Cylinder and Linkage

8 ft. 9 in. (2.66 m)	3,635 lb. (1649 kg)
10 ft. 6 in. (3.2 m)	3,876 lb. (1758 kg)
13 ft. 1 in. (4.0 m)	4,184 lb. (1898 kg)
Boom Lift Cylinders (2) Total Weight	1,248 lb. (624 kg)
2.3-cu.-yd. (1.76 m ³), 54-in. (1370 mm)	
Heavy-Duty Bucket	2,557 lb. (1160 kg)
Counterweight	16,314 lb. (7400 kg)

Lifting Capacities

Boldface italic type indicates hydraulic-limited capacities; lightface type indicates stability-limited capacities, in lb. (kg). Ratings at bucket lift hook; machine equipped with 2.3-cu.-yd. (1.76 m³), 54-in. (1370 mm), 2,557-lb. (1160 kg) bucket; 16,314-lb. (7400 kg) counterweight; standard gauge; and situated on firm, uniform supporting surface. Total load includes weight of cables, hook, etc. Figures do not exceed 87 percent of hydraulic capacities or 75 percent of weight needed to tip machine. All lift capacities are based on SAE J1097.

Load Point Height	15 ft. (4.57 m)		20 ft. (6.10 m)		25 ft. (7.62 m)		30 ft. (9.15 m)		35 ft. (10.67 m)	
	Over Front	Over Side	Over Front	Over Side	Over Front	Over Side	Over Front	Over Side	Over Front	Over Side
<i>With 13-ft. 1-in. (4.0 m) arm and 32-in. (800 mm) triple semi-grouser shoes</i>										
20 ft. (6.10 m)							12,273 (5567)	9,996 (4534)		
15 ft. (4.57 m)					14,199 (6441)	13,721 (6224)	13,451 (6101)	9,724 (4411)		
10 ft. (3.05 m)	26,701 (12 111)	26,701 (12 111)	19,872 (9014)	18,786 (8521)	16,581 (7521)	12,937 (5868)	14,716 (6675)	9,301 (4219)	10,208 (4630)	6,785 (3078)
5 ft. (1.52 m)	34,222 (15 523)	26,533 (12 035)	24,420 (11 077)	17,264 (7831)	19,101 (8664)	12,116 (5496)	14,871 (6745)	8,838 (4009)	11,358 (5152)	6,557 (2974)
Ground Line	27,003 (12 248)	24,933 (11 310)	27,623 (12 530)	16,161 (7331)	19,411 (8805)	11,440 (5189)	14,433 (6547)	8,436 (3827)	11,143 (5054)	6,356 (2883)
-5 ft. (-1.52 m)	25,662 (11 640)	24,473 (11 101)	27,191 (12 334)	15,588 (7071)	18,937 (8590)	11,014 (4996)	14,147 (6417)	8,174 (3708)		
-10 ft. (-3.05 m)	28,325 (12 848)	24,540 (11 131)	27,018 (12 255)	15,438 (7003)	18,768 (8513)	10,862 (4927)	14,080 (6387)	8,111 (3679)		
-15 ft. (-4.57 m)	32,496 (14 740)	24,977 (11 329)	25,622 (11 622)	15,636 (7092)	18,930 (8587)	11,008 (4993)				
-20 ft. (-6.10 m)	25,530 (11 580)	25,530 (11 580)	19,607 (8894)	16,245 (7369)						
<i>With 10-ft. 6-in. (3.2 m) arm and 32-in. (800 mm) triple semi-grouser shoes</i>										
25 ft. (7.62 m)					10,000 (4536)	10,000 (4536)				
20 ft. (6.10 m)					14,638 (6640)	13,905 (6307)	9,472 (4296)	9,472 (4296)		
15 ft. (4.57 m)					16,151 (7326)	13,371 (6065)	15,044 (6824)	9,511 (4314)		
10 ft. (3.05 m)	32,447 (14 718)	27,999 (12 700)	22,606 (10 254)	18,134 (8226)	18,339 (8319)	12,640 (5733)	15,199 (6894)	9,157 (4154)		
5 ft. (1.52 m)			26,577 (12 055)	16,793 (7617)	19,917 (9034)	11,915 (5405)	14,777 (6703)	8,768 (3977)		
Ground Line	19,237 (8726)	19,237 (8726)	27,598 (12 518)	15,968 (7243)	19,313 (8760)	11,372 (5158)	14,439 (6549)	8,458 (3837)		
-5 ft. (-1.52 m)	18,735 (8498)	18,735 (8498)	27,226 (12 349)	15,646 (7097)	18,999 (8618)	11,091 (5031)	14,276 (6476)	8,309 (3769)		
-10 ft. (-3.05 m)	24,351 (11 046)	24,351 (11 046)	27,279 (12 374)	15,692 (7118)	18,998 (8617)	11,090 (5030)				
-15 ft. (-4.57 m)	29,437 (13 353)	25,623 (11 623)	23,225 (10 535)	16,080 (7294)	17,270 (7834)	11,462 (5199)				
<i>With 8-ft. 9-in. (2.66 m) arm and 32-in. (800 mm) triple semi-grouser shoes</i>										
20 ft. (6.10 m)					16,071 (7290)	13,686 (6208)				
15 ft. (4.57 m)			20,080 (9108)	19,184 (8702)	17,400 (7893)	13,183 (5980)	15,444 (7005)	9,394 (4261)		
10 ft. (3.05 m)			24,277 (11 012)	17,736 (8045)	19,413 (8806)	12,487 (5664)	15,127 (6862)	9,103 (4129)		
5 ft. (1.52 m)			27,773 (12 598)	16,530 (7498)	19,799 (8981)	11,826 (5364)	14,763 (6696)	8,769 (3978)		
Ground Line			27,493 (12 471)	15,899 (7212)	19,292 (8751)	11,370 (5157)	14,497 (6576)	8,525 (3867)		
-5 ft. (-1.52 m)	22,873 (10 375)	22,873 (10 375)	27,301 (12 384)	15,733 (7136)	19,086 (8657)	11,185 (5073)	14,446 (6553)	8,478 (3846)		
-10 ft. (-3.05 m)	19,509 (8849)	19,509 (8849)	26,307 (11 933)	15,900 (7212)	19,213 (8715)	11,299 (5125)				
-15 ft. (-4.57 m)	26,093 (11 836)	26,088 (11 833)	20,977 (9515)	16,439 (7457)						

Buckets

A full line of buckets is offered to meet a wide variety of applications. Digging forces are with power boost. Tooth selection includes either the John Deere Fanggs®, Standard, Tiger, Twin Tiger, Abrasion panel, or Flare tooth, or the ESCO (Vertalok) Standard, Tiger, Twin Tiger, or Flare tooth. Replaceable cutting edges are available through Hitachi parts. Optional side cutters add 6 inches (150 mm) to bucket widths.

Type Bucket	Bucket Width		Bucket Capacity*		Weight		Bucket Dig Force		Arm Dig Force 8 ft. 9 in. (2.66 m)		Arm Dig Force 10 ft. 6 in. (3.2 m)		Arm Dig Force 13 ft. 1 in. (4.0 m)		Bucket Tip Radius		No. Teeth
	in.	mm	cu. yd.	m ³	lb.	kg	lb.	kN	lb.	kN	lb.	kN	lb.	kN	in.	mm	
General-Purpose Plate Lip	48	1219	2.03	1.55	2,115	959	48,220	214.5	43,730	194.5	38,030	169.2	32,682	145.4	63.0	1600	6
	54	1372	2.30	1.76	2,215	1005	48,220	214.5	43,730	194.5	38,030	169.2	32,682	145.4	63.0	1600	7
	60	1524	2.59	1.98	2,338	1061	48,220	214.5	43,730	194.5	38,030	169.2	32,682	145.4	63.0	1600	7
General-Purpose High Capacity	48	1219	2.15	1.64	2,815	1277	43,712	194.4	42,090	187.2	36,768	163.5	31,747	141.2	69.5	1765	5
	54	1372	2.45	1.87	2,982	1353	43,712	194.4	42,090	187.2	36,768	163.5	31,747	141.2	69.5	1765	6
	60	1524	2.74	2.09	3,089	1401	43,712	194.4	42,090	187.2	36,768	163.5	31,747	141.2	69.5	1765	7
Heavy-Duty Plate Lip	36	914	1.48	1.13	2,138	970	48,220	214.5	43,730	194.5	38,030	169.2	32,682	145.4	63.0	1600	4
	42	1067	1.75	1.34	2,210	1002	48,220	214.5	43,730	194.5	38,030	169.2	32,682	145.4	63.0	1600	5
	48	1219	2.03	1.55	2,324	1054	48,220	214.5	43,730	194.5	38,030	169.2	32,682	145.4	63.0	1600	6
	54	1372	2.30	1.76	2,557	1160	48,220	214.5	43,730	194.5	38,030	169.2	32,682	145.4	63.0	1600	6
Heavy-Duty High Capacity	30	762	1.26	0.96	2,516	1141	43,712	194.4	42,090	187.2	36,768	168.5	31,747	141.2	69.5	1765	4
	36	914	1.56	1.19	2,781	1261	43,712	194.4	42,090	187.2	36,768	168.5	31,747	141.2	69.5	1765	4
	42	1067	1.85	1.41	3,120	1415	43,712	194.4	42,090	187.2	36,768	168.5	31,747	141.2	69.5	1765	5
	48	1219	2.15	1.64	3,318	1505	43,712	194.4	42,090	187.2	36,768	168.5	31,747	141.2	69.5	1765	6
	54	1372	2.45	1.87	3,562	1616	43,712	194.4	42,090	187.2	36,768	168.5	31,747	141.2	69.5	1765	6

*All capacities are SAE heaped ratings and with side cutters.

Bucket Selection Guide*

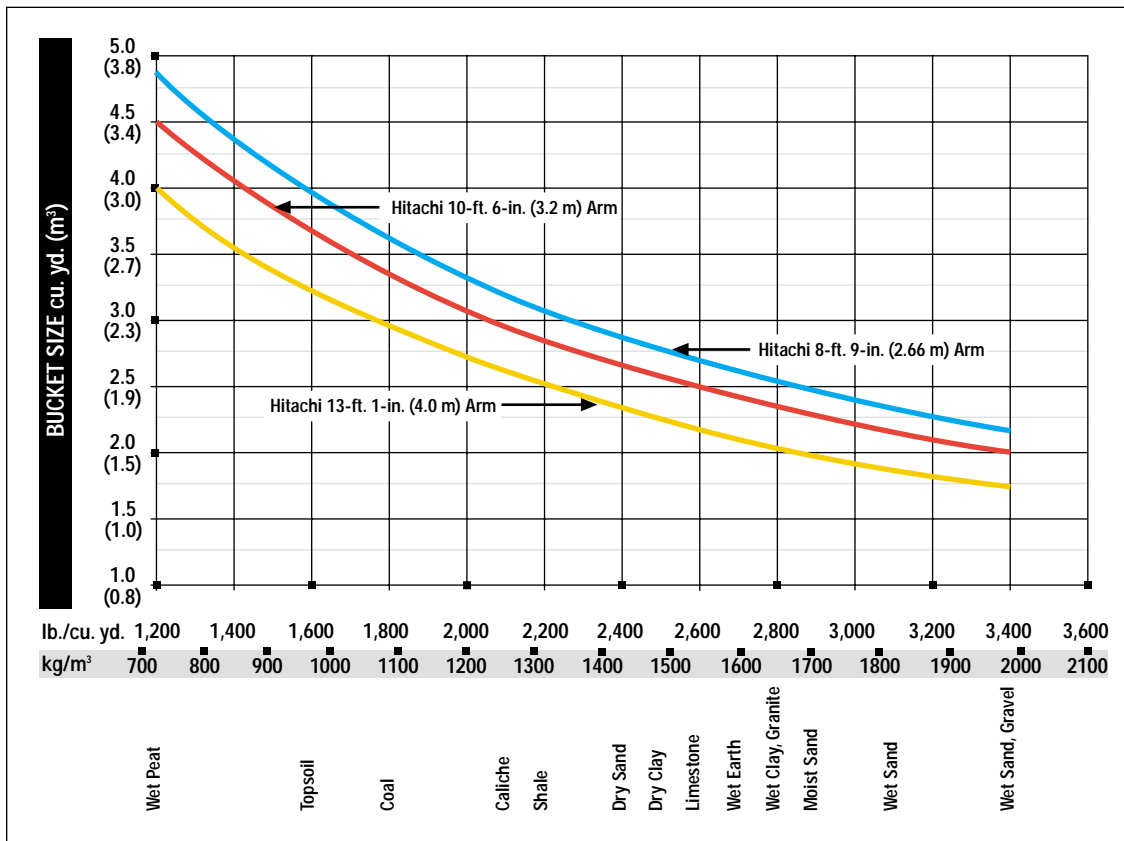

*Contact your Hitachi dealer for optimum bucket and attachment selections. These recommendations are for general conditions and average use. Does not include optional equipment such as thumbs or couplers. Larger buckets may be possible when using light materials, for flat and level operations, less compacted materials, and volume loading applications such as mass excavation applications in ideal conditions. Smaller buckets are recommended for adverse conditions such as off-level applications, rocks, and uneven surfaces. Bucket capacity indicated is SAE heaped.

Dimensions

A	8-ft. 9-in. (2.66 m) arm.....	11 ft. 5 in. (3.47 m)
	10-ft. 6-in. (3.2 m) arm.....	10 ft. 9 in. (3.27 m)
	13-ft. 1-in. (4.0 m) arm.....	11 ft. 10 in. (3.60 m)
B	8-ft. 9-in. (2.66 m) arm.....	36 ft. 6 in. (11.13 m)
	10-ft. 6-in. (3.2 m) arm.....	36 ft. 1 in. (11.00 m)
	13-ft. 1-in. (4.0 m) arm.....	36 ft. 5 in. (11.09 m)

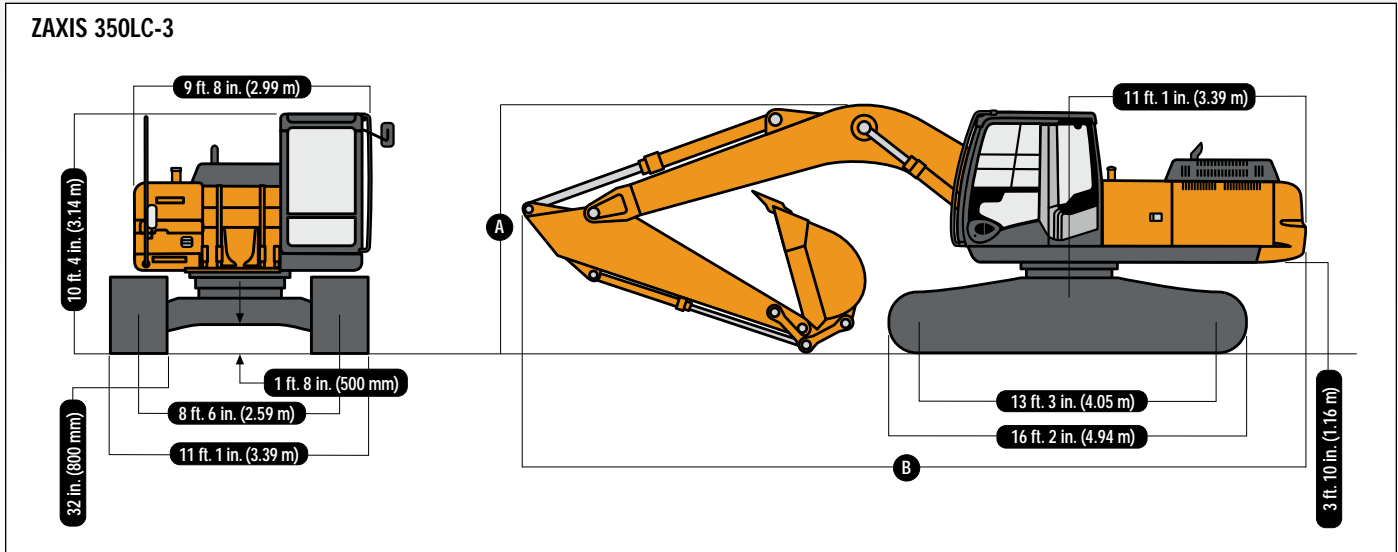

Operating Information

	Arm Length 8 ft. 9 in. (2.66 m)	Arm Length 10 ft. 6 in. (3.2 m)	Arm Length 13 ft. 1 in. (4.0 m)
Arm Force with 32-in. (800 mm) Triple Semi-Grouser Shoes*	43,730 lb. (194.5 kN)	38,030 lb. (169.2 kN)	32,682 lb. (145.4 kN)
Bucket Digging Force with 32-in. (800 mm) Triple Semi-Grouser Shoes*	48,220 lb. (241.5 kN)	48,220 lb. (241.5 kN)	48,220 lb. (241.5 kN)
Lifting Capacity Over Front @ Ground Level.....	27,493 lb. (12 470 kg)	27,598 lb. (12 518 kg)	27,623 lb. (12 530 kg)
A Maximum Reach	34 ft. 8 in. (10.57 m)	36 ft. 5 in. (11.10 m)	38 ft. 11 in. (11.86 m)
A' Maximum Reach @ Ground Level.....	34 ft. 0 in. (10.36 m)	35 ft. 9 in. (10.89 m)	39 ft. 1 in. (11.97 m)
B Maximum Digging Depth	22 ft. 5 in. (6.84 m)	24 ft. 3 in. (7.38 m)	26 ft. 10 in. (8.18 m)
B' Maximum Digging Depth @ 8-ft. (2.44 m) Flat Bottom	21 ft. 9 in. (6.64 m)	23 ft. 8 in. (7.21 m)	26 ft. 5 in. (8.04 m)
C Maximum Cutting Height	32 ft. 9 in. (9.99 m)	34 ft. 0 in. (10.36 m)	35 ft. 3 in. (10.75 m)
D Maximum Dumping Height	22 ft. 9 in. (6.94 m)	23 ft. 9 in. (7.24 m)	25 ft. 0 in. (7.63 m)
E Minimum Swing Radius	15 ft. 2 in. (4.61 m)	14 ft. 7 in. (4.46 m)	14 ft. 8 in. (4.47 m)
F Maximum Vertical Wall	18 ft. 1 in. (5.51 m)	21 ft. 1 in. (6.42 m)	23 ft. 10 in. (7.27 m)
G Tail Swing Radius	11 ft. 1 in. (3.38 m)	11 ft. 1 in. (3.38 m)	11 ft. 1 in. (3.38 m)

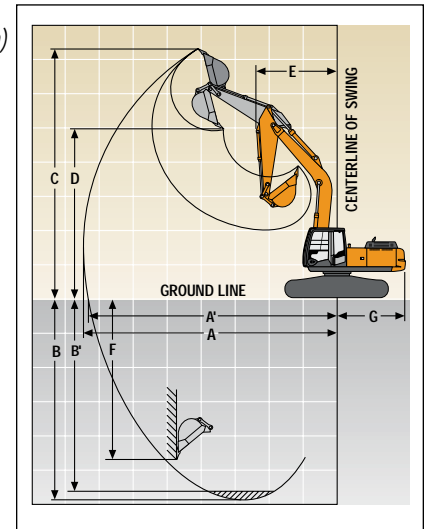

*Digging forces and lift capacities with power boost.

Equipment

Key ● Standard Equipment ▲ Optional or Special Equipment

Engine

- H/P mode control
- E mode control
- 50 A alternator
- Dry-type air filter with evacuator valve (with air filter restriction switch for monitor)
- Cartridge-type engine oil filter
- Cartridge-type fuel double filters
- Air cleaner double filters
- Radiator, oil cooler and intercooler with dust protective net
- Radiator reserve tank
- Fan guard
- Isolation-mounted engine
- Auto-idle system
- Fuel cooler
- Electrical fuel feed pump
- Engine oil drain coupler

Hydraulic System

- Reduced-drift valve for boom down, arm in
- Auxiliary hydraulic valve section
- Spring-applied, hydraulically released automatic swing brake
- Auxiliary hydraulic-flow adjustments through monitor
- Auto power lift
- 5,000-hour hydraulic-oil-change interval
- Hydraulic-oil-sampling valve
- ▲ Auxiliary hydraulic lines
- ▲ Auxiliary pilot and electric controls
- ▲ Hydraulic filter restriction indicator kit
- ▲ Load-lowering control device
- ▲ Single-pedal propel control
- ▲ Control pattern change valve

Undercarriage

- Planetary drive with axial piston motors
- Propel motor shields
- Spring-applied, hydraulically released automatic propel brake
- Track guides, front idler and three additional
- Two-speed propel with automatic shift
- Upper carrier rollers (2)
- Sealed and lubricated track chain
- Triple semi-grouser shoes, 32 in. (800 mm)

Upperstructure

- Right- and left-hand mirrors
- Vandal locks with ignition key: Cab door / Fuel cap / Service doors / Toolbox
- Debris-screening side panel
- Remote-mounted engine oil and fuel filters

Front Attachments

- Centralized lubrication system
- Dirt seals on all bucket pins
- Less boom and arm
- Oil-impregnated bushings
- Reinforced resin thrust plates
- Tungsten carbide thermal coating on arm-to-bucket joint
- ▲ Arm, 8 ft. 9 in. (2.66 m)
- ▲ Arm, 10 ft. 6 in. (3.2 m)
- ▲ Arm, 13 ft. 1 in. (4.0 m)
- ▲ Attachment quick-couplers
- ▲ Boom cylinder with plumbing to mainframe for less boom and arm
- ▲ Buckets: General purpose / General-purpose high capacity / Heavy duty / Heavy-duty high capacity / Side cutters and teeth
- ▲ Material clamps
- ▲ Super-long fronts

Operator's Station

- Adjustable independent control positions (levers-to-seat, seat-to-pedals)
- AM/FM radio
- Auto climate control/air conditioner, 20,000 Btu/hr. (5.9 kW) with heater and pressurizer
- Built-in Operator's Manual storage compartment and manual
- Cell-phone power outlet, 12 volt, 60 watt, 5 amp
- Coat hook
- Deluxe suspension cloth seat with 4-in. (100 mm) adjustable armrests
- Floor mat
- Front windshield wiper with intermittent speeds
- Gauges (illuminated): Engine coolant / Fuel
- Horn, electric
- Hourmeter, electric
- Hydraulic shutoff lever, all controls
- Hydraulic warm-up control

- Interior light
- Large cup holder
- Machine Information Center (MIC)
- Mode selectors (illuminated): Power modes – three / Travel modes – two with automatic shift / Work mode – one
- Multifunction, color LCD monitor with: Diagnostic capability / Multiple-language capabilities / Maintenance tracking / Clock / Theft-deterrent system / System monitoring with alarm features: Auto-idle indicator, engine air cleaner restriction indicator light, engine check, engine coolant temperature indicator light with audible alarm, engine oil pressure indicator light with audible alarm, low-alternator-charge indicator light, low-fuel indicator light, fault code alert indicator, fuel-rate display, wiper-mode indicator, work-lights-on indicator, and work-mode indicator
- ▲ Monitor system with alarm features: Hydraulic oil filter restriction indicator light
- Motion alarm with cancel switch (conforms to SAE J994)
- Power-boost switch on right console lever
- Auxiliary hydraulic control switches in right console lever
- SAE two-lever control pattern
- Seat belt, 2 in. (51 mm), retractable
- ▲ Seat belt, 3 in. (76 mm), non-retractable
- Tinted glass
- Transparent tinted overhead hatch
- Hot/cold beverage compartment
- ▲ Air-suspension heated seat
- ▲ 24- to 12-volt D.C. radio convertors, 10 amp
- ▲ Circulation fan
- ▲ Protection screens for cab front, rear, and side
- ▲ Window vandal protection covers

Electrical

- 50-amp alternator
- Blade-type multi-fused circuits
- Positive terminal battery covers
- ▲ Cab extension wiring harness

Lights

- Work lights: Halogen / One mounted on boom / One mounted on frame

Control Owning and Operating Costs

Customer Personal Service (CPS) is part of Hitachi's proactive, fix-before-fail strategy on machine maintenance that will help control costs, increase profits, and reduce stress. Included in this comprehensive lineup of ongoing programs and services are:

Fluid analysis program – tells you what's going on inside all of your machine's major components so you'll know if there's a problem before you see a decline in performance. Fluid analysis is included in most extended coverage and preventive-maintenance agreements.

Preventive Maintenance (PM) agreements – give you a fixed cost for maintaining a machine for a given period of time. They also help you avoid downtime by ensuring that critical maintenance work gets done right and on schedule. On-site preventive maintenance service performed where and when you need it helps protect you from the expense of catastrophic failures and lets you avoid waste-disposal hassles.

Extended coverage – gives you a fixed cost for machine repairs for a given period of time so you can effectively manage expenses. Whether you work in a severe-service setting, or you just want to spread the risk

of doing business, this is a great way to custom-fit coverage to your operation. An extended coverage contract also travels well because it's backed by the company and is honored by all Hitachi dealers.

Customer Support Advisors (CSAs) – the CSA program lends a personal quality to Customer Personal Service (CPS). Certified CSAs have the knowledge and skills for helping make important decisions on machine maintenance and repair. Their mission is to help you implement a plan that's right for your business and take the burden of machine maintenance off your shoulders.

Net engine power is with standard equipment including air cleaner, exhaust system, alternator, and cooling fan, at standard conditions per SAE J1349 and DIN 6270B, using No. 2-D fuel at 35 API gravity. No derating is required up to 10,000-ft. (3050 m) altitude. Gross power is without cooling fan. Specifications and design subject to change without notice. Wherever applicable, specifications are in accordance with SAE standards. Except where otherwise noted, these specifications are based on a unit with 54-in. (1340 mm) bucket, 32-in. (800 mm) triple semi-grouser shoes, 16,314 lb. (7400 kg) counterweight, full fuel tank, and 175 lb. (79 kg) operator.