

60XT Skid Steer



ENGINE

Model Case 4-390 diesel
Type..... 4-stroke, naturally aspirated
Cylinders..... 4
Bore/Stroke 4.02" x 4.72"
(102 x 120 mm)
Displacement 239 in³ (3.9 L)
Fuel injection..... Direct
Fuel..... #2 Diesel
Fuel filter..... In-line strainer
Air intake Cross-flow
Cooling Liquid
Engine speeds (rpm)
High idle - no load..... 2450±50
Rated - full load 2200
Low idle..... 950
Horsepower per SAE J1349
Gross..... 75 (55.9 kW) @ 2200 rpm
Net 69 (51 kW) @ 2200 rpm
Peak torque
@ 1200 rpm 193 lb-ft (262 N·m)

ENGINE COOLING

Radiator
Core type Square wave
serpentine
Core size area.... 165.9 in² (.107 m²)
Rows of tubes 5
Cap pressure 14.9 psi (103 kPa)
Fan
Diameter 20.4" (518 mm)
Ratio 1.1:1
Water pump
Style Integral
Flow..... 45 gpm (170 L/min)
Engine lubrication
Pump..... Deep sump plate cooler
with pressurized
under-piston nozzles
Pump operating angle ratings
Side-to-side..... Rated 45°
Fore and aft Rated 45°
Oil filtration Replaceable,
full-flow cartridge

POWERTRAIN

Drive pump Tandem, axial piston
hydrostatic transmission
w/integral charge pump driven
directly off engine flywheel
Pump to engine ratio..... 1:1
Displacement ... 0 to 2.81 in³ (46 cc)
Pump flow @ rated rpm... 26.7 gpm
(101 L/min)
Flow Bi-directional
Charge pressure ... 400 psi (27.6 bar)
System relief 5004 psi
(345 bar)
Controls Servo
Drive motors Fixed displacement
high torque, low-speed gerotor
motor with shuttle valve
Maximum displacement.... 30.7 in³
(503 cc)
Speed @ rated engine rpm
@ max displacement..... 183 rpm
Torque @ max displacement
and relief pressure..... 1,752 lb-ft
(2383 N·m)
Travel speed 7.0 mph
(11.3 km/h)
Final drive..... Single-reduction
chain drive
Drive chain
Size..... ASA #100HS
Tensile strength 30,000 lb
(133 447 N)
Axles..... One-piece, forged
induction-hardened
high carbon steel
Torque @ rated rpm 4,906 lb-ft
(6651 N·m)
Diameter 2.0" (51 mm)
Length 14.61" (371 mm)
Parking brakes Pin lock
Engagement Raise seat bar

HYDRAULIC SYSTEM

Standard equipment
Pump Gear pump
Displacement ... 2.32 in³/rev (38 cc)
Pump flow @ rated engine rpm
Total 21.0 gpm (79.4 L/min)
Loader control valve..... 2-spool
open-center series with
power beyond port
Relief pressure.... 3000 psi (207 bar)
Port relief pressures
#1A Lower..... 3800 psi (262 bar)
#1B Raise 3100 psi (214 bar)
#2A Rollback.... 3800 psi (262 bar)
#2B Dump 3100 psi (214 bar)
#3A & B Auxiliary None
Hydraulic lines
Tubing 37° JIC Flare
Loop hoses SAE 100 R12
Swing-out hydraulic oil cooler
Core type Four row in-line
Hydraulic filters 6-micron,
spin-on replaceable element
for the return line with
warning indicator
Filter capacity
Return line filter 0.2 oz (27 g)

INSTRUMENTATION

Digital hourmeter
 Fuel level LED bar graph
 Warning lights
 Fuel level
 Voltage
 Engine coolant temperature
 Engine oil pressure
 Air cleaner restriction
 Hydraulic filter restriction
 Hydraulic oil temperature
 Systems normal
 Seat belt reminder
 Warning alarms
 Engine coolant temperature
 Engine oil pressure
 Hydraulic oil temperature
 Seat belt reminder

ELECTRICAL SYSTEM

Alternator..... 65 amp
 Starter 2.5 kW
 Battery 12-volt low-maintenance
 610 cold-cranking amps
 @ 0° F (-18° C)

OPERATOR ENVIRONMENT

Tilt ROPS/FOPS canopy
 w/side screens
 Water-shedding vinyl seat
 Seat presence switch
 2" (51 mm) retractable seat belt
 Seat bar w/integral armrests
 Two servo-assist, adjustable,
 hands-only control levers
 Hand throttle
 Loader control lockout system
 Front and rear halogen floodlights
 Floor cleanout access

CYLINDERS

Lift cylinder
 Bore diameter..... 2.50" (63.5 mm)
 Rod diameter 1.50" (38.1 mm)
 Stroke 35.83" (2066 mm)
 Closed length 46.85" (1190 mm)
 Bucket cylinder
 Bore diameter..... 2.75" (69.9 mm)
 Rod diameter 1.375" (34.9 mm)
 Stroke 14.5" (369 mm)
 Closed length..... 26.9" (683 mm)

OPERATING WEIGHTS

Unit equipped with 12.00 x 16.5
 Solideal Hauler SKS tires,
 66" (1.6 m) short lip bucket,
 mechanical attachment coupler,
 full fuel and 165 lb (75 kg)
 operator 6,562 lb (2977 kg)
 Shipping weight... 5,894 lb (2673 kg)

Add-on weights

Side cab glass..... +70 lb (32 kg)
 Lexan® door..... +50 lb (22.6 kg)
 Glass door w/wiper... +77 lb (35 kg)
 Floor heater +20 lb (9.1 kg)
 Suspension seat +10 lb (4.5 kg)

SERVICE CAPACITIES

Fuel tank..... 22.0 gal (83.3 L)
 Engine oil w/filter 11 qt (10.4 L)
 Engine oil w/o filter..... 10 qt (9.5 L)
 Engine cooling system... 17.5 qt (16.6 L)
 Hydraulic system
 Reservoir..... 7.1 gal (32.4 L)
 Total 13.3 gal (50.2 L)
 Chain tanks (per side).... 6 qt (5.7 L)

TIRE SELECTION

	Size	Ply Rating	Tread Depth	Tire Width	Width Over Tires	Tire Weight*	Max Travel Speed
Galaxy Mighty Slim Jim	33/10.00 x 16.5.....	10.....	0.81" (21 mm)	10.2" (259 mm)	59" (1.50 m)	72 lb (32.7 kg)	7.0 mph (11.3 km/h)
Solideal Hauler SKS.....	12.00 x 16.5.....	10.....	0.75" (19 mm)	13.1" (333 mm)	64" (1.63 m)	51 lb (23.1 kg)	7.0 mph (11.3 km/h)
Solideal Hauler SKS (offset wheel)	12.00 x 16.5.....	10.....	0.75" (19 mm)	13.1" (333 mm)	71" (1.80 m)	51 lb (23.1 kg)	7.0 mph (11.3 km/h)
Galaxy Beefy Baby II	12.00 x 16.5.....	10.....	0.81" (21 mm)	12.4" (315 mm)	64" (1.63 m)	81 lb (36.7 kg)	7.0 mph (11.3 km/h)
Galaxy Beefy Baby (offset wheel) II.....	12.00 x 16.5.....	10.....	0.81" (21 mm)	12.4" (315 mm)	71" (1.80 m)	81 lb (36.7 kg)	7.0 mph (11.3 km/h)
Galaxy Hippo.....	33/15.50 x 16.5.....	12.....	0.81" (21 mm)	15.2" (386 mm)	70" (1.78 m)	96 lb (43.6 kg)	7.0 mph (11.3 km/h)
Galaxy King Kong.....	12.00 x 16.5	12.....	1.25" (32 mm)	12.6" (320 mm)	64" (1.63 m)	96 lb (43.6 kg)	7.0 mph (11.3 km/h)
Galaxy Hulk.....	12.00 x 16.5.....	12.....	1.37" (35 mm)	12.0" (304 mm)	64" (1.63 m)	100 lb (45.4 kg)	7.0 mph (11.3 km/h)
Galaxy Bulky Hulk.....	33/15.50 x 16.5.....	14.....	1.37" (35 mm)	15.1" (384 mm)	70" (1.78 m)	124 lb (56.2 kg)	7.0 mph (11.3 km/h)

NOTE: *Tire weight does not include wheel weight.

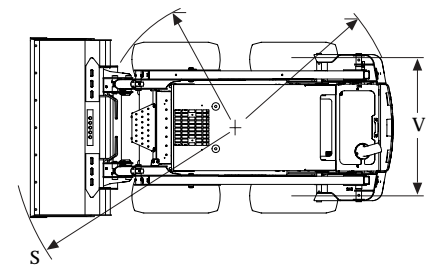
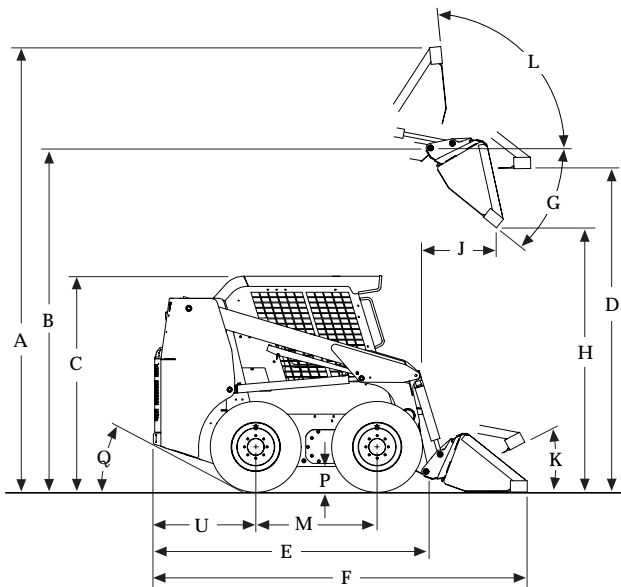

DIMENSIONS

- A.** Overall operating height
w/foundry/excavating bucket – short lip 152.8” (3.88 m)
w/low profile bucket – standard lip 158.0” (4.01 m)
w/low profile extended bucket – long lip 163.0” (4.14 m)
- Height to*
- B.** Bucket hinge pin 121.5” (3.09 m)
C. Top of rollover protective structure 76.7” (1.95 m)
D. Bottom of level bucket, loader arm fully raised 114.2” (2.90 m)
- Overall length
- E.** w/o attachment w/coupler 103.9” (2.64 m)
F. w/foundry/excavating bucket on ground 127.2” (3.23 m)
F. w/low profile bucket on ground 132.9” (3.38 m)
F. w/low profile extended bucket on ground 137.9” (3.50 m)
- G.** Dump angle at maximum height 39°
- H.** Dump height – loader arm fully raised
w/foundry/excavating bucket 96.6” (2.45 m)
w/low profile bucket 93.1” (2.37 m)
w/low profile extended bucket 90.0” (2.29 m)
- J.** Reach – loader arm fully raised
w/foundry/excavating bucket 21.3” (0.54 m)
w/low profile bucket 25.9” (0.66 m)
w/low profile extended bucket 29.7” (0.75 m)
- Maximum attachment rollback
- K.** Bucket on ground 32°
L. Bucket at full height 84°
- M.** Wheelbase 43.1” (1.10 m)
- Ground clearance
- P.** Bottom of belly pan 9” (229 mm)
Q. Angle of departure 28°
- Clearance circle front
- R.** Less bucket 50.3” (1.28 m)
S. w/66” (1.68 m) foundry/excavating bucket on ground 76.7” (1.95 m)
S. w/66” (1.68 m) low profile bucket on ground 81.9” (2.08 m)
S. w/66” (1.68 m) low profile extended bucket on ground 83.1” (2.20 m)
T. Clearance circle rear 59.1” (1.50 m)
U. Rear axle to bumper 36.6” (0.93 m)
V. Tread width, centerline to centerline 52.6” (1.34 m)

NOTE: *Equipped with 12.00 x 16.5 Solideal Hauler SKS tires.

PERFORMANCE SPECS

- Operating load 1,800 lb (817 kg)
Tipping load 3,600 lb (1633 kg)
Breakout force
Lift cylinder 4,431 lbf
(19 710 N)
Bucket cylinder 5,054 lbf
(22 482 N)
- Dig depth
w/bucket flat 0” (0 mm)
- Cycle time
Raise 4.1 seconds
Lower 3.2 seconds
Dump 2.1 seconds
Rollback 1.7 seconds

NOTE: SAE rated lift capacities. Breakout force and cycle time measured with rated load in D/F bucket.

OPTIONAL BUCKETS

Type	Width inch (m)	Weight lb (kg)	Heaped
			Capacity ft ³ (m ³)
Foundry/ Excavating ...	60	270	11.5
	(1.5)	(122)	(0.33)
	66	370	15.2
	(1.6)	(168)	(0.43)
	72	390	16.7
Low Profile ...	78	495	18.4
	(2.0)	(225)	(0.52)
	66	400	13.2
	(1.6)	(181)	(0.37)
	72	425	14.5
Low Profile Extended ...	(1.8)	(193)	(0.41)
	60	360	14.3
	(1.5)	(163)	(0.40)
	66	434	15.5
	(1.6)	(197)	(0.44)
Utility/Light Material ...	72	477	17.1
	(1.8)	(216)	(0.48)
	78	502	18.6
	(2.0)	(228)	(0.53)
	60	350	19.7
Manure/ Slurry ...	(1.5)	(159)	(0.56)
	72	434	23.7
	(1.8)	(197)	(0.67)
	84	497	27.9
	(2.1)	(225)	(0.79)
Manure/ Slurry ...	60	340	16.7
	(1.5)	(154)	(0.47)
	72	465	19.1
(1.8)	(211)	(0.54)	

STANDARD EQUIPMENT

OPERATOR'S COMPARTMENT

ROPS/FOPS canopy w/side screens
Tilt ROPS/FOPS
Instrument panels
Water-shedding vinyl seat
2" (51 mm) retractable seat belt
Hand throttle
Ergonomic hand controls
Seat bar w/integral armrests
Loader control lockout system
Floor cleanout panel

LOADER

Radial loader arm design
Mechanical attachment coupler

ENGINE

Case 4-390 diesel
Automatic fan belt tensioner
Integral engine oil cooling
Fuel filter w/water trap
Dual element air cleaner
65 amp alternator
610 CCA 12-volt battery
Heavy-duty radiator

POWERTRAIN

Hydrostatic four wheel drive
Servo controls
ASA #100HS drive chain
Parking brakes

HYDRAULICS

Auxiliary hydraulics 3000 psi
(207 bar) – 21.0 gpm (79.4 L/min)
Hydraulic circuit pedal lock
Loader arm-mounted ISO flat face
connectors
Loader function lockout system
Loader lockout override
2-spool loader control valve
Loader arm float position

OTHER

Integral bumper counterweight
Lockable service access hood
Single-point daily servicing
Halogen lights, 2-front, 1-rear
Rear tail lights

OPTIONAL EQUIPMENT

OPERATOR'S COMPARTMENT

Vinyl suspension seat w/2"
(51 mm) retractable seat belt
Vinyl suspension seat w/3"
(76 mm) retractable seat belt
Auxiliary front electric controls
Chassis options harness
Lexan® front door
Glass front door w/wiper & washer
Sliding side windows
Heater (deluxe)
Rear window w/emergency escape
feature
Top window
Foot throttle
Accessory power outlet

LOADER

Ride control
Hydraulic attachment coupler
Hydraulic two-way self-leveling

HYDRAULICS

High-flow auxiliary hydraulics
3000 psi (207 bar)
31.9 gpm (121 L/min)

ENGINE

Coolant block heater
Thermostart

OTHER

Backup alarm
Rotating beacon
Lift hooks
Horn
Special paint
Language decals
Factory-installed tires – see page 2
Buckets – see page 3
Bolt-on spill guards
Bolt-on bucket cutting edges
42" (1.07 m) and 48" (1.22 m)
pallet forks
Model D125 backhoe
Auxiliary front electric
Ride control
Remote jump start
Battery disconnect switch
Automatic engine shutdown system
Steel tracks

FIELD-INSTALLED OPTIONS

Floor heater
Auto-engine shutdown

NOTE: All specifications are stated in accordance with SAE Standards or Recommended Practices, where applicable.

Form No. CE 300-05-01
Replaces Form No. - None

Case is a registered trademark of Case Corporation.



IMPORTANT: Case Corporation reserves the right to change these specifications without notice and without incurring any obligation relating to such change. Case Corporation does not warrant the safety or reliability of attachments from other manufacturers.

Visit Case Corporation on the Web at:
<http://www.casece.com>
Printed in U.S.A.

60XT Page 4 of 4

Lexan is a trademark of the General Electric Co.
Galaxy, Beefy Baby and Hippo are trademarks of
the Galaxy Tire Co. Hauler SKS is a trademark of
Solideal Industrial Tires, Inc.

© 2001 CASE CORPORATION
All Rights Reserved.

CASE CONSTRUCTION EQUIPMENT CONTACT INFORMATION

NORTH AMERICA/MEXICO
700 STATE STREET
RACINE, WI 53404 U.S.A.